

DOUBLE 2x BEVEL SPLINES W/ 3"
CONST. LAGS @ 24" O.C. OR 16d
NAILS @ 12" O.C. IN 2 ROWS
STAGGERED W/ PANEL SEALANT
BETWEEN 2x's (U.N.O.)

PRE-ASSEMBLED VIEW
(WITHOUT TOP PLATES)

7/16" OSB SKINS ON
BOTH SIDES, TYPICAL

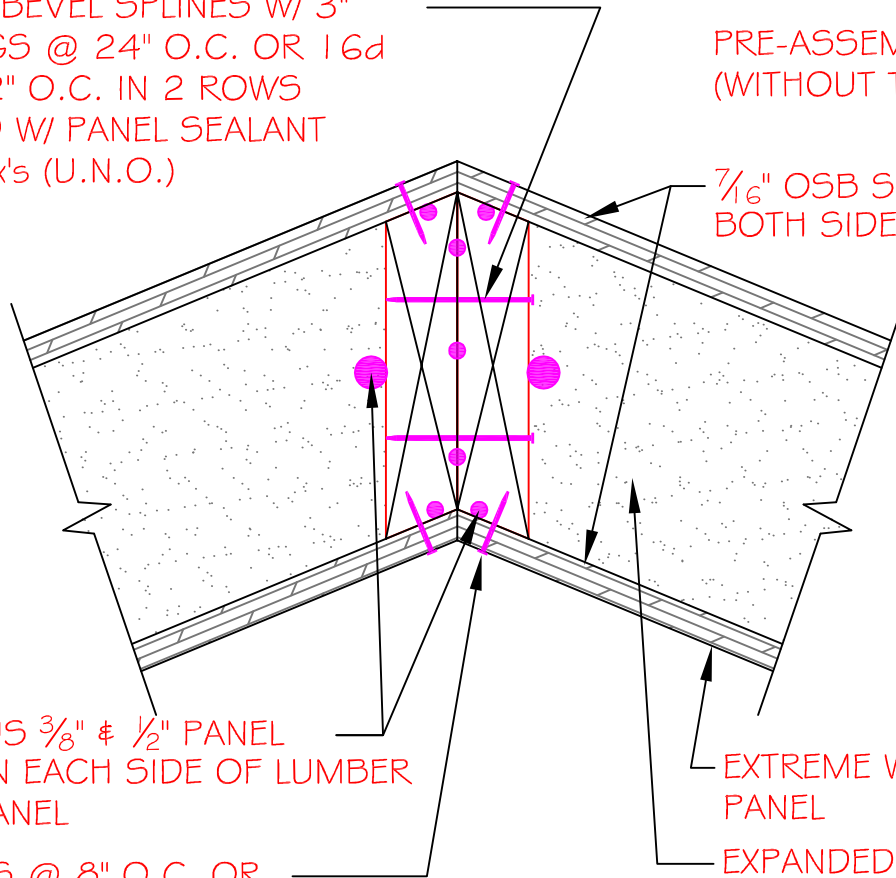

CONTINUOUS 3/8" x 1/2" PANEL
SEALANT ON EACH SIDE OF LUMBER
ON EACH PANEL

EXTREME WALL
PANEL

EXPANDED
POLYSTYRENE CORE

1 1/2" SCREWS @ 8" O.C. OR
2"-8d NAILS @ 6" O.C. BOTH
SIDES, TOP AND BOTTOM
(U.N.O.)

ASSEMBLED VIEW

TOP PLATES

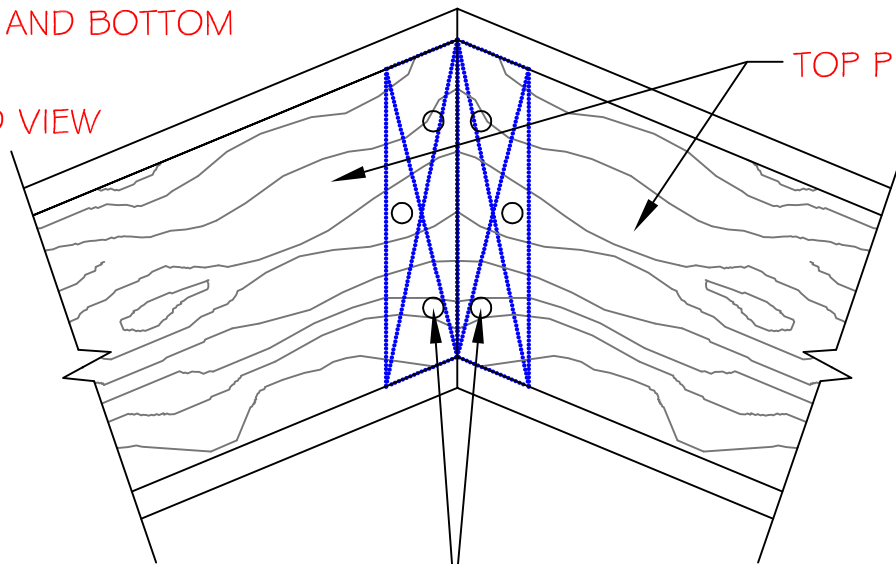

SCREW OR NAIL THE
TOP PLATE TO THE
VERTICAL STUD WITH
(2) 3" CONST. LAGS
OR
(3) 16d NAILS

SECTION
NOT TO SCALE

DETAIL TITLE : ANGLED CORNER CONNECTION

DETAIL NO. : EP-114

PAGE NO. : 1 - 14

UPDATED : MARCH 2017

Extreme Panel

TECHNOLOGIES, INC.

STRUCTURAL INSULATED PANELS