

SIP HEADER: SIP AS A STRUCTURAL HEADER.
SEE EPT-407 OR EPT-408 FOR ASSEMBLY SEQUENCE.

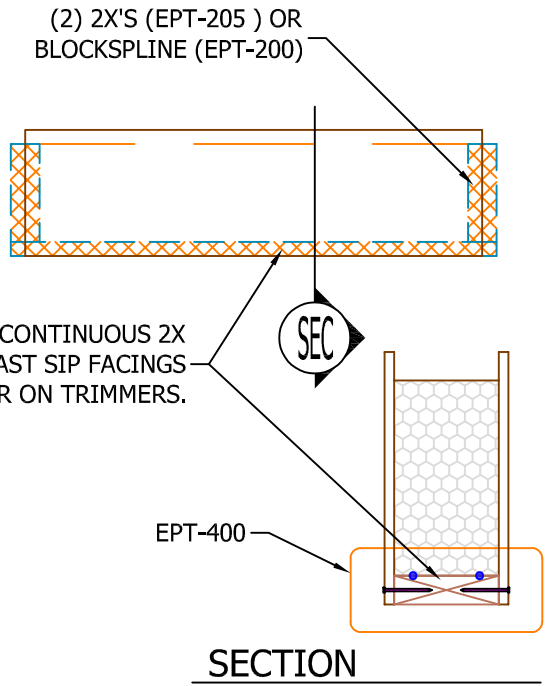

IHDR-1 PLY: INSULATED HEADER (1) PLY LVL.
SEE EPT-407 OR EPT-408 FOR ASSEMBLY SEQUENCE.

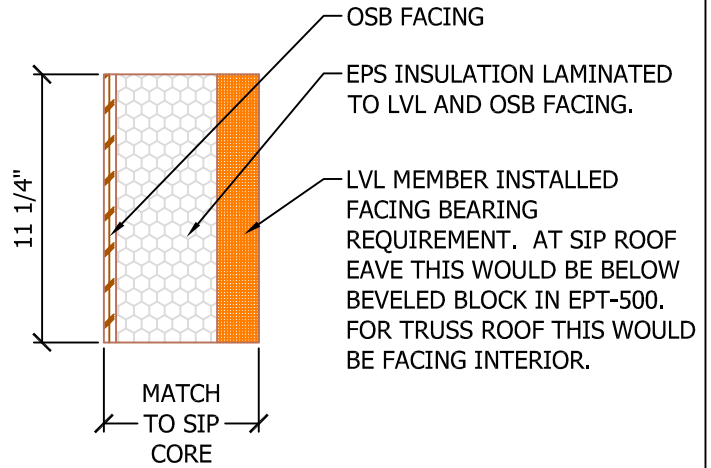

IHDR-2 PLY: INSULATED HEADER (2) PLY LVL.
SEE EPT-407 OR EPT-408 FOR ASSEMBLY SEQUENCE.

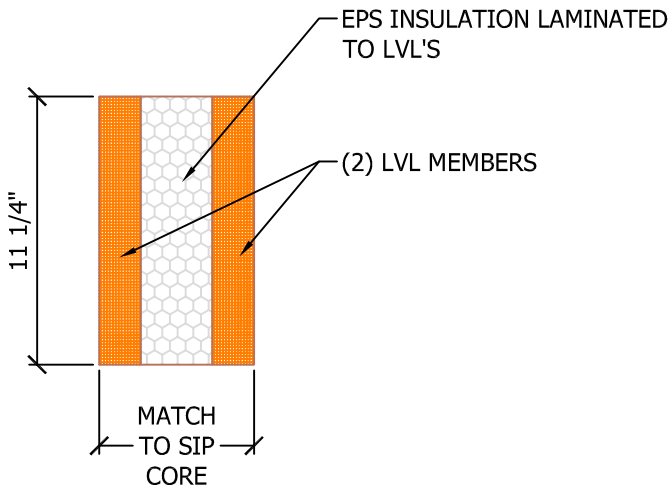

HBO: HEADER BY OTHERS.
SEE EPT-407 OR EPT-408 FOR ASSEMBLY SEQUENCE.

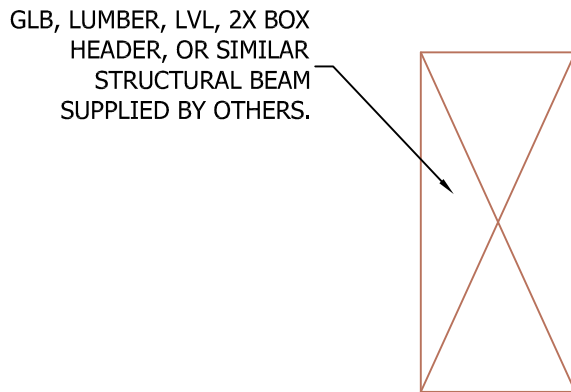

N.T.S.

Rev: 12/10/2021

EPT-411

HEADER ASSEMBLIES