



## ICC-ES Listing Report

### ESL-1644

Issued January 2025

This listing is subject to renewal January 2026.

**CSI:** DIVISION: 06 00 00—WOOD, PLASTICS AND COMPOSITES  
Section: 06 12 00—Structural Panels

#### Product Certification System:

The ICC-ES product-certification system includes evaluated evidence in support of test data in accordance with the standard listed below. The system also involves factory inspections, and assessment and surveillance of the listee's quality system.

**Product:** PREMIER STRUCTURAL INSULATED PANELS (SIPS)

**Listee:** PREMIER BUILDING SYSTEMS, LLC.

#### Additional Listees:

BIG SKY INSULATION, INC.

EXTREME PANEL TECHNOLOGIES

**Evaluation:** The Premier SIPs, described in ICC-ES Evaluation Report, ESR-4524, have been evaluated as components in a wall assembly described in the ICC Design No. WPC-1644-01 to the following standard:

- NFPA 285-23, Standard Fire Test Method for the Evaluation of Fire Propagation Characteristics of Exterior Non-load-bearing Wall Assemblies Containing Combustible Components, National Fire Protection Association.

**Findings:** The wall assembly constructed with the Premier SIPs has met the performance criteria in accordance with NFPA 285, as result of the testing to the recognized standard indicated above. Relevant code sections where the standard is referenced are listed below. Approval of the product's use and all other relevant code sections is the sole responsibility of the local code (building) official.

- 2024 *International Building Code*® (IBC)  
Applicable Section: 2603.5.5
- 2024 *International Residential Code*® (IRC)  
Applicable Section: R301.1.3

#### Identification:

1. The ICC-ES mark of conformity, electronic labeling, or the listing report number (ICC-ES ESL-1644) along with the name, registered trademark, or registered logo of the listee must be included in the product label.
2. In addition, each Premier SIP or the package material must bear a product label, containing the name of the listee (Premier Building Systems, LLC) or additional listees (Big Sky Insulation, Inc. or Extreme Panel Technologies), the production date and/or lot number, and the plant code or manufacturing address.
3. The report holder's contact information is the following:

**PREMIER BUILDING SYSTEMS, LLC**  
18504 CANYON ROAD EAST  
PUYALLUP, WASHINGTON 98375  
(800) 275-7086  
[www.premiersips.com](http://www.premiersips.com)

4. The additional listees' contact information is the following:

**BIG SKY INSULATION, INC.**  
15 ARDEN DRIVE  
BELGRADE, MONTANA 59714  
(406) 388-4146

**EXTREME PANEL TECHNOLOGIES**  
475 EAST 4TH STREET NORTH  
COTTONWOOD, MINNESOTA 56229  
(507) 828-0798

**Installation:** The Premier SIPs must be installed in accordance with the Premier Building System, LLC's published installation instructions and applicable codes.

**Conditions of Listing:**

1. The listing report addresses only conformance with the standard and code sections noted above.
2. The listing applies only to the materials tested and as submitted for review by ICC-ES. Evaluation is limited to the NFPA 285 test data. See [ESR-4524](#) for compliance of the Premier SIPs with other applicable requirements of the IBC and IRC.
3. Capacities of the supporting members and embedment of fasteners in the supporting member must be checked by a registered design professional as they may control the design.
4. Premier SIPs are manufactured under a quality control program with inspections by ICC-ES.

**Applicant:** PREMIER BUILDING SYSTEMS, LLC.  
**Product:** PREMIER STRUCTURAL INSULATED PANEL  
**Standard:** NFPA 285

WPC = Wood, Plastics and Composites

Refer to Table 1 on next page for item number designations.

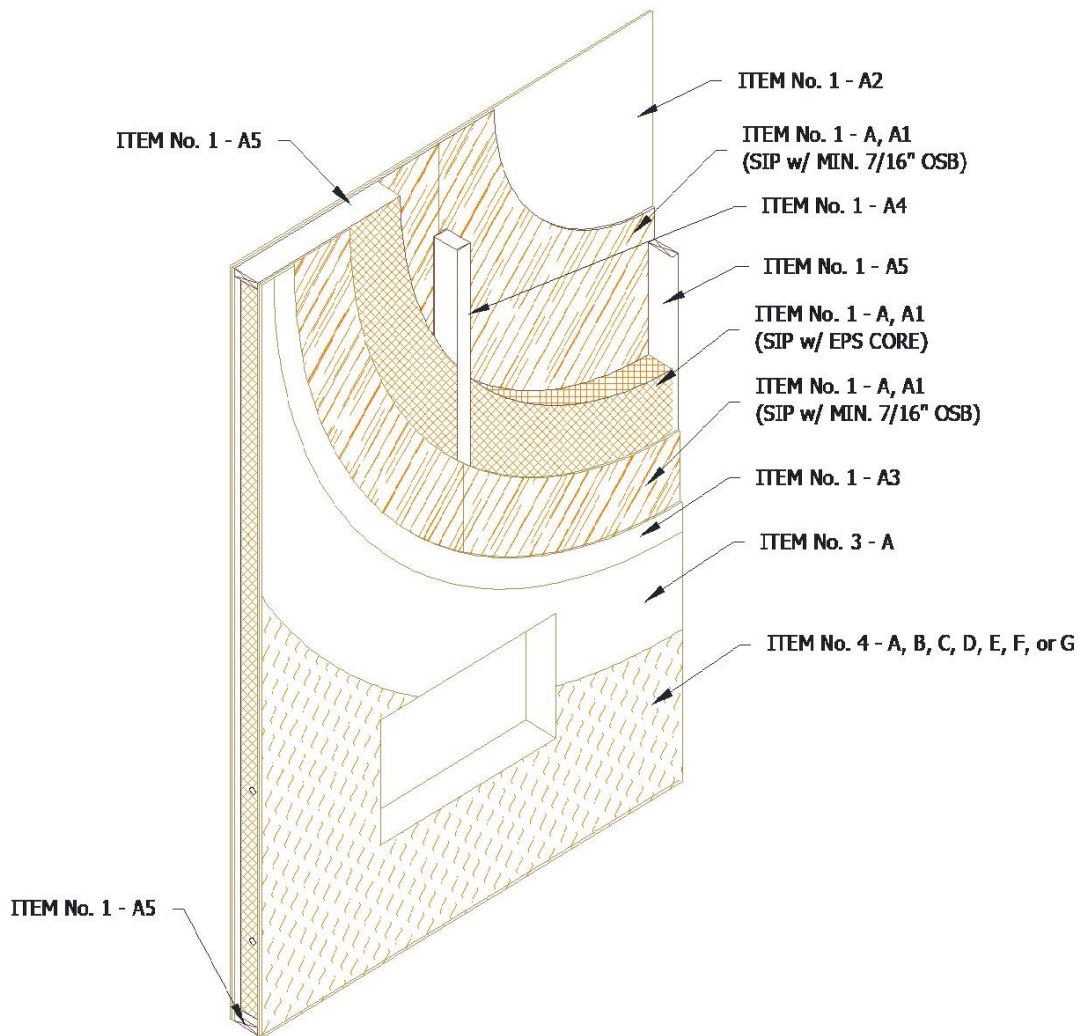

**FIGURE 1—NFPA 285 WALL ASSEMBLY CONSTRUCTED WITH PREMIER SIPS (ESR-4524)  
(NOT TO SCALE)**

## COMPONENTS OF CONSTRUCTION:

TABLE 1 – FOR COMPLIANCE WITH NFPA 285-23 ICC DESIGN NO. WPC-1644-01

ITEM NO.	WALL COMPONENTS	MATERIALS
1	Base Wall <sup>1,2</sup>	<p><b>A — Base Wall:</b> The base wall must be constructed with the following components:</p> <p><b>A1: Structural Insulated Panels (SIPs):</b> Premier SIPs (<a href="#">ESR-4524</a>) in nominal panel thickness of 4<sup>1</sup>/<sub>2</sub>, 6<sup>1</sup>/<sub>2</sub>, 8<sup>1</sup>/<sub>4</sub>, 10<sup>1</sup>/<sub>4</sub>, or 12<sup>1</sup>/<sub>4</sub> inches without any horizontal joints in the field of the SIP.</p> <p><b>A2: Interior Sheathing:</b> One layer of nominal 5/<sub>8</sub>-inch-thick (15.9 mm) Type X gypsum wallboard, complying with ASTM C1396, installed on the interior face of the Premier SIPs.</p> <p><b>A3: Exterior Sheathing:</b> One layer of nominal 5/<sub>8</sub>-inch-thick (15.9 mm) Type X glass-mat gypsum sheathing, complying with ASTM C1177, installed on the exterior face of the Premier SIPs.</p> <p><b>A4: SIP-to-SIP Connection:</b> Nominal 2x Box or Block splines (Type S) with the same thickness as the SIP core, installed into the recess of Premier SIPs and secured with one ring shank sheathing nail, measuring 2<sup>3</sup>/<sub>8</sub>-inch (60.3 mm) in length by 0.113-inch (2.9 mm) in diameter, spaced at 6 inches (152 mm) on each side of the Premier SIPs joint. Premier SIP sealant (<a href="#">ESR-4524</a>) must be applied at the interface between the core and box or block spline in accordance with the manufacturer's published installation instructions.</p> <p><b>A5: Boundary Elements:</b> Nominal 2x solid sawn lumber, having the same thickness of the panel core, installed into the recessed core of the Premier SIPs at the panel top, side and bottom perimeter edges. The lumber must be secured with one ring shank sheathing nail, measuring 2<sup>3</sup>/<sub>8</sub>-inch (60.3 mm) in length by 0.113-inch (2.9 mm) in diameter, spaced at 6 inches (152 mm) on each side of the perimeter of the panels. Premier SIP sealant (<a href="#">ESR-4524</a>) must be applied at the interface between the core and box or block spline in accordance with the manufacturer's published installation instructions. See Figure 2 for applications of the Premier SIP sealant.</p> <p><b>Note:</b> The exterior wall assembly must be limited to the wall height (panel span) specified in <a href="#">ESR-4524</a>, Table 5, based on the Premier SIPs panel thickness.</p>
2	Floorline Firestopping (Not Shown): Use A	<p><b>A —</b> Non-combustible mineral wool safing (minimum density of 4.0 lbs./ft<sup>3</sup>) must be installed at each floorline between the floor slab and interior sheathing (gypsum wallboard). Mineral wool must be attached with z-clips or friction-fit.</p>
3	Water-Resistive Barrier <sup>3</sup> : Use A.	<p><b>A —</b> Premier SIPs Building Wrap (Prime Wrap) must be installed over the exterior sheathing Item No. 1 (A3) with Primewrap sheathing tape applied at all seams.</p> <p><b>Note:</b> No air gap is permitted between the water-resistive barrier and the exterior wall covering (Item No. 4).</p>
4	Exterior Wall Covering <sup>4</sup> : Use A, B, C, D, E, F, or G  Note: No air gap is permitted between the water-resistive barrier and the exterior wall covering.	<p><b>A — Brick:</b> Standard nominally 4-inch-thick clay brick with brick veneer anchors installed a maximum of 24 inches on center vertically.</p> <p><b>B — Stucco:</b> Minimum 3/<sub>4</sub>-inch-thick, code-complying exterior cement plaster and lath.</p> <p><b>C — Natural stone veneer:</b> Minimum 2-inch-thick, using any standard closed joint installation technique.</p> <p><b>D — Cast artificial stone:</b> Minimum 1<sup>1</sup>/<sub>2</sub>-inch-thick complying with ICC-ES AC51 (Adhered Manufactured Stone Masonry Veneer) and subject of a current ICC-ES evaluation report, using any standard closed joint installation technique.</p> <p><b>E — Fiber-cement siding:</b> Minimum 5/<sub>16</sub>-inch-thick, classified as non-combustible when tested in accordance with ASTM E136, using any standard closed joint installation technique.</p> <p><b>F — Uninsulated sheet metal building panels:</b> Steel, Aluminum, and Copper, installed using any standard joint installation technique.</p> <p><b>G — Exterior Insulation Finishing System (EIFS):</b> A code-complying EIFS that has been tested in accordance with, and complies with, the 2023 edition of NFPA 285 and is recognized in a current ICC-ES evaluation report (ESR) for the EIFS. The EIFS must be installed in accordance with the installation specified in the ICC-ES evaluation report (ESR) for the EIFS with the exception that the exterior sheathing must be as described above in Item No. 1 (A3) of the base wall (nominal 5/<sub>8</sub>-inch-thick, ASTM C1177 complying, Type X glass-mat gypsum sheathing).</p>
5	Window Perimeter and Rough Opening Protection <sup>5</sup> : Use A (A1, A2 and A3) and See Figure 3 for details.	<p><b>A —</b> Window perimeter and rough opening must be reinforced with dimensional lumber framing members designed in accordance with Section 4.1.7 of ESR-4524 to resist applied axial, transverse and in plane shear loads around the openings and protected with the use of the following materials:</p> <p><b>A1 — Perimeter Members:</b> Nominal 2x solid sawn lumber, having the same thickness of the panel core, installed into the recessed core of the Premier SIPs along the perimeter of the window opening. The lumber must be secured with one ring shank sheathing nail, measuring 2<sup>3</sup>/<sub>8</sub>-inch (60.3 mm) in length by 0.113-inch (2.9 mm) in diameter, spaced at 6 inches (152 mm) on center on each side of the Premier SIPs panels. Premier SIP sealant (<a href="#">ESR-4524</a>) must be applied at the interface between the core and box or block spline in accordance with the manufacturer's published installation instructions</p> <p><b>A2 — Gypsum Sheathing Protection:</b> One layer of nominal 5/<sub>8</sub>-inch-thick Type X glass-mat gypsum sheathing complying with ASTM C1177 must be installed over the nominal 2x solid sawn lumber installed between the interior and exterior gypsum wall board sheathing. The gypsum wall board sheathing must be installed with two 1<sup>1</sup>/<sub>4</sub>-inch-long, No. 6 Type W bugle head drywall screws spaced at 12 inches on center and 1 inch in from the edge of the gypsum sheathing.</p> <p><b>A3 — Perimeter Protection:</b> The interior edge of the window opening must be covered with paper-faced metal corner bead embedded within a thin layer of the joint compound.</p>

For SI: 1 inch = 25.4 mm, 1 foot = 304.8 mm, 1 pcf = 16.01 kg/m<sup>3</sup>.

**Footnotes to Table 1:**

<sup>1</sup>Interior sheathing (nominal 5/8-inch-thick (15.9 mm) Type X gypsum wallboard) must be installed with 1 1/4 inches long No. 6 Type W bugle head drywall screws, spaced at a maximum of 8 inches on center along the perimeter of the gypsum wall boards and 16 inches on center horizontally and 12 inches on center vertically in the field of gypsum wall boards. Joints of gypsum wall boards must be sealed with paper tape and joint compound. The screw heads must be covered with joint compound.

<sup>2</sup>Exterior sheathing must be installed with 1 1/4 inches long No. 6 Type W bugle head drywall screws, spaced at a maximum of 8 inches on center along the perimeter of the gypsum wall boards and 16 inches on center horizontally and 12 inches on center vertically in the field of gypsum wall boards. Joints of gypsum wall boards and the screw heads may be covered with joint compound.

<sup>3</sup>Water-resistive barrier (WRB) must be installed over the exterior sheathing in accordance with the applicable code, the manufacturer's published installation instructions, and the current ICC-ES evaluation report. This material was evaluated by ICC-ES to comply with IBC Section 2603.5, when used as part of the wall assembly outlined in Table 1, but has not been evaluated for use as a water-resistive barrier under IBC Section 1404.2 and IRC Section R703.2.

<sup>4</sup>Exterior wall covering must be designed to support the self-weights and wind pressure in accordance with applicable code. Fasteners used to install the exterior cladding must be installed by penetrating into the wood framing and/or the exterior OSB facer of the SIPs, depending on the exterior cladding design.

<sup>5</sup>Window perimeter and rough opening protection options are related to the NFPA 285 tested assembly only. Requirements for opening flashing and waterproofing shall be in accordance with the window manufacturer's published installation instructions.

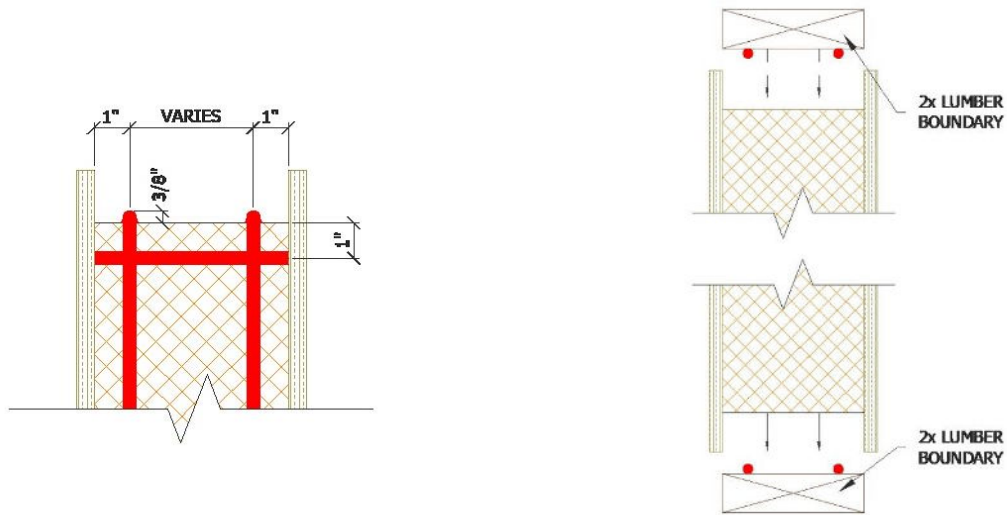

**FIGURE 2—TYPICAL APPLICATION OF PREMIER SIP SEALANT**

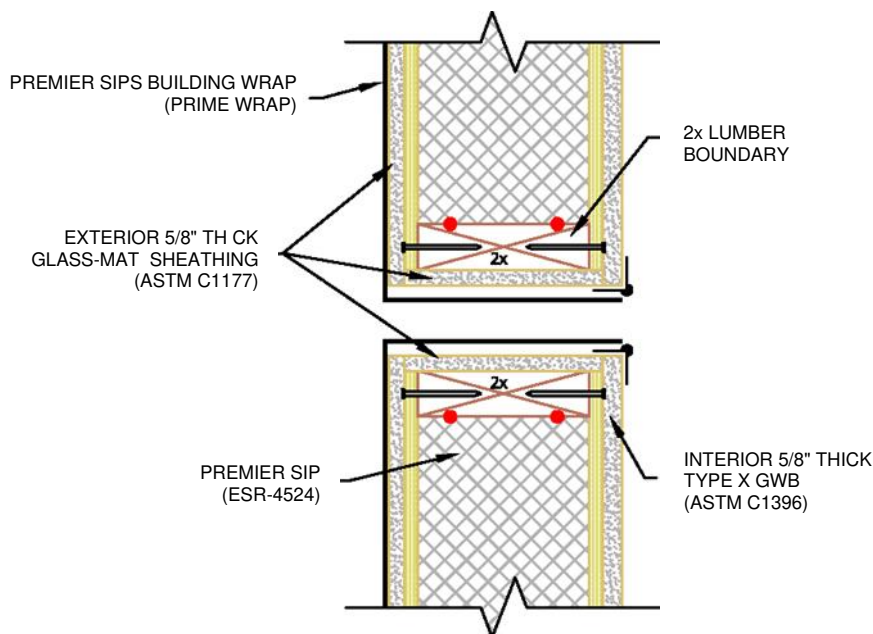

**FIGURE 3—TYPICAL DETAIL FOR WINDOW OPENING PROTECTION (NOT TO SCALE)**