

**9' Foundation  
SIPs  
Detail Manual  
(On Concrete Footings)**



**Pinnacle**  
ENGINEERING



**EXTREME PANEL  
TECHNOLOGIES**

800-977-2635  
[extremepanel.com](http://extremepanel.com)

# TABLE OF CONTENTS

---

---

## FOUNDATIONS ON CONCRETE FOOTINGS

### 9' EXTREME BASEMENT SIPs

INSTALLATION GUIDELINES .....	PAGE 1-4
BELOW GRADE 8" FOUNDATION SIP DETAIL .....	PAGE 5-6
BRACING DETAIL .....	PAGE 7-12

## SUPPLEMENTAL INSERTS

TYPES OF SOILS & RELATED DESIGN PROPERTIES.....	PAGE 13
---	---------



8180 Corporate Park Drive (513) 984-1663  
Suite 235 www.pinneng.com  
Cincinnati, Ohio 45242 projects@pinneng.com  
DBA Pinnacle Engineering, Inc. of Ohio P.C.

I hereby certify that this plan,  
specification, or report was  
prepared by me or under my  
direct supervision and that I am  
a duly Licensed Professional  
Engineer under the laws of the  
State of Minnesota.

Name: Thomas A. Moore

Signature: *Thomas A. Moore*

Date: 01-24-2025 License: #57458

Thomas A Moore  
Digitally signed by Thomas A Moore  
DN: cn=Thomas A Moore, c=US,  
email=tmoores@pinneng.com  
Date: 2025.01.24 16:08:06 -05'00'

# 9' Foundation SIPs (On Concrete Footings)

1. The type of soil is a factor in determining foundation construction details such as footing design, backfill, and drainage provisions. Soils are classified by their composition and how they drain. Soil classifications for most areas are listed in the standard series of soil surveys published by the U.S. Department of Agriculture's Soil Conservation Service. Extreme's Foundation SIPs may be built in Group I, II, or III soils. In poorly drained Group III soils, granular fill under slab for basement type foundations must be 6" deep instead of the 4" minimum for Group I and II soils. Group IV soils are generally not recommended for Extreme's Foundation SIPs, unless special measures are taken. For building sites in areas where expansive clay soils in Group II, III, or IV occur, a licensed soils engineer should be consulted to determine modifications required for foundation footings, drainage, soil moisture control, and back fill around the foundation. In such cases, special design considerations and construction details may be needed to avoid soil expansion or shrinkage which might otherwise affect foundation and floor performance. For basement type foundations, a sump, draining to daylight or into a storm sewer is recommended for all soil types. (Refer to attached "Table 1-Types of soils and related design properties" from Southern Pine Council PWF Design & Construction Guide. [www.southernpine.com](http://www.southernpine.com)).

2. Granular materials are recommended for footings under Extreme's Foundation SIPs, but continuous poured concrete may also be used for footings. Granular materials are to be used for fill under the basement slab and a portion of the backfill to provide an optimum drainage system. The granular material may be crushed stone, gravel or sand, and must be clean and free of silt, clay, and organic material. Limitations are:

- Maximum of 1/2" for crushed stone

- Maximum of 3/4" for gravel

- Minimum of 1/16" for sand

3. Footings need to be placed on undisturbed soil and the footing excavation should extend below the frost line. To achieve proper frost protection for low backfill heights like where egress windows are located, either the footing needs to be excavated to the proper depth or a layer of 3 1/2" expanded polystyrene foam or 2" extruded polystyrene foam (min. r-value requirement of 10.5). Insulation is to be placed horizontal at a height of 10" from the bottom of the footing to allow proper drainage. It is to be a strip a minimum of 24" wide and extend a minimum of 24" past on both sides of the opening.

4. For concrete footings, typically minimum size of 8" thick by 16" wide and a minimum compressive strength of 2500 lbs., it is recommended to place the footing on 4" of granular material to maintain continuity of the drainage system, otherwise 3" drains at 6' o.c. must be provided through the concrete footings. In Group I and II soils, place a minimum of 4" of granular fill and for Group III soils use a minimum of 6" of granular fill under the slab, for proper drainage to a Sump pit located in the interior or exterior of the foundation. With Group I soils, granular material can be used for drainage on the outside of the foundation as long as it is covered by a 6 mil poly sheeting or water permeable filter fabric to prevent soil from washing into the footing. In Group II and III soils it is recommended that a 4" perforated tile be placed at same grade level as the footing and covered with a filter cloth to keep the perforations open. This tile along with the granular bed under the slab needs to be sloped toward the sump to drain properly. Alternative drainage systems like Form-A-Drain can be used for both the concrete forms and the drainage system for the concrete footings. An automatic electric sump pump will be needed if the sump cannot be drained by gravity to daylight or to a storm sewer system.

5. Anchor the .60 CCA treated 2x8 to the concrete footing using 1/2" x 8" galvanized anchor bolts 4' o.c. and located within 12" from the end of each plate section. Remember to set the plates in 5/8" from outer dimensions of the structure to allow for exterior skin of SIP to fit on the outside of the plate.

6. Install Extreme's Foundation SIPs according to the SIP shop drawings provided. Use SIP Adhesive/Sealant for all wood to wood connections and for all wood to foam or foam to foam connections. Refer to Extreme Panel's Construction Detail Manual for placement of these products. Nail all SIP connections using 2" stainless steel (type 304 or 316) ring shank nails 8" o.c.. These materials are supplied by Extreme Panels. Any other alternative products need to be approved by Extreme Panels. Note: If a pneumatic nailer is used, do not drive the heads of the nails in any deeper than 1/8". Top plates (typically not treated) are to be installed with the ends of the top plates staggered to not fall on the seam of a SIP vertical connection.

7. Seal exterior joints in the plywood using 4" SIP Flashing which is supplied by Extreme Panels. SIP Adhesive/Sealant can also be used.

8. Floor systems: OPTION 1: **For a maximum backfill height of 8'-4"**, floor systems need to be hung on the inside of Extreme's Foundation SIPs using top mount joist hangers designed for the floor system being used. The 3/4" decking is to be extended over the top plate of the SIPs to the outside edge of the structure. For bracing the foundation walls that are running parallel to the Floor Trusses/Joists require LVL blocks the depth of the Floor Truss/Joist in the first 2 Truss/Joist bays. Blocks are to be centered on vertical glulam a maximum of every 4'-0" o.c. Apply SIP Adhesive/Sealant where blocking meets subfloor. Install a minimum of four (4) nails through subfloor into each block. Toenail at the bottom of the blocks on each side into the truss and wall.

8. cont. Also apply an angle clip (Simpson Strong-Tie A35 Framing Angle with Bend Slot) with (12) 8d x 1 1/2" nails to the block connecting to the wall. See attached details for further placement and number of A35 angles needed for different types of Truss/Joist hanging or stacking situations. Any strong-back bracing that the floor joist manufacturer requires will need to be installed also, typically this is a vertical 2x6 placed 10' o.c.. Refer to SIP layout to place solid blocking required through floor system for point loads from structure above.

**OPTION 2: For a maximum backfill height of 7'-4" and higher finished ceiling height**, floor systems can be stacked on top of the Extreme Foundation SIPs. Extreme's Insulated Rimboard must be used with the sill plate being attached to the top plate of the SIPs using SIP Adhesive/Sealant and #9x3" screws or 16d nails 6" o.c. staggered. Refer to Extreme Panel's Construction Detail Manual for installation guidelines for the rimboard itself. Set the floor system that has been designed for the structure according to their layout. Fasten the floor joists to the top plate of the SIP using (3) #9x3" screws or (3) 16d nails. Two angle clips (Simpson Strong-Tie A35 Framing Angle with Bend Slot) to secure joist to top plate with (12) 8d x 1 1/2" nails. For bracing the foundation walls that are running parallel to the Floor Trusses/Joists require LVL blocks the depth of the Floor Truss/Joist in the first 2 Truss/Joist bays. Blocks are to be centered on vertical glulam a maximum of every 4'-0" o.c. Apply SIP Adhesive/Sealant where blocking meets subfloor. Install a minimum of four (4) nails through subfloor into each block. Toenail at the bottom of the blocks on each side into the truss and wall. Also apply an A35 Angle to the block connecting to the wall. See attached details for further placement and number of A35 angles needed for different types of Truss/Joist hanging or stacking situations. Any strong-back bracing that the floor/joist manufacturer requires will need to be installed also, typically this is a vertical 2x6 placed 10' o.c.. Refer to SIP shop drawings to place solid blocking required through floor system for point loads from structure above.

Interior supports for floor framing may be posts and girder beams or unsheathed .60 CCA treated 2x6 lumber (untreated if built above concrete) built wall. For lumber built wall, align studs w/ joist or use double top plates. Wall can be placed on concrete footing designed the same as exterior foundation or placed on a granular footing with a 2x10 .60 CCA treated base plate and .60 CCA treated sill plate. For high concentration loads, footing size may have to be increased.

9. Concrete floor installation: Concrete floor is to be poured a minimum of 3 1/2" thick, a minimum compressive strength of 2500 lbs., and 2" up on the SIP from the bottom of the plywood. A 1x screed board is optional along base of SIP.

10. Below grade moisture barrier: 6 mil poly is to be applied over the below grade portion of the foundation. A single layer is adequate, but 2 layers is suggested for extra protection when backfilling. Poly is to be draped over the footing, but is not to extend over the drainage tile. Joints in the poly are to be lapped a minimum of 6" and sealed with SIP Adhesive/Sealant. The top edge of the poly is to be bonded to the SIP to create a seal. This is to be achieved by using at least a 12" treated plywood strip or other strips can be used for architectural treatment. Before strip is installed, a continuous seal of SIP Adhesive/Sealant is to be applied between the wall and strip. The strip needs to extend at least 9" below grade.

11. Backfilling: Backfilling is not permitted until basement floor and first floor have been constructed. A maximum backfill height depends on the floor system design used from #8 of this document. If the floor is hung on the inside of the SIP, then 8'-4" is permitted. If the floor system is stacked on top of the SIP, then 7'-4" is permitted. Granular material is to be used for backfill. Backfill a distance of 2'-0" out from the wall and 2/3 the height of the total backfill height. Granular material is then to be covered with either 30 pound asphalt paper or 6 mil poly to allow for water seepage while avoiding infiltration of fine soils. The remaining of the backfill can use the same type of soil as was removed during the excavation. Finish grade is to slope a 1/2" per foot a minimum of 6'-0" from structure.

12. Interior surface of SIPs may need to be covered with a fire retardant with the equivalent of 1/2" sheetrock if it is going to be used for living space.

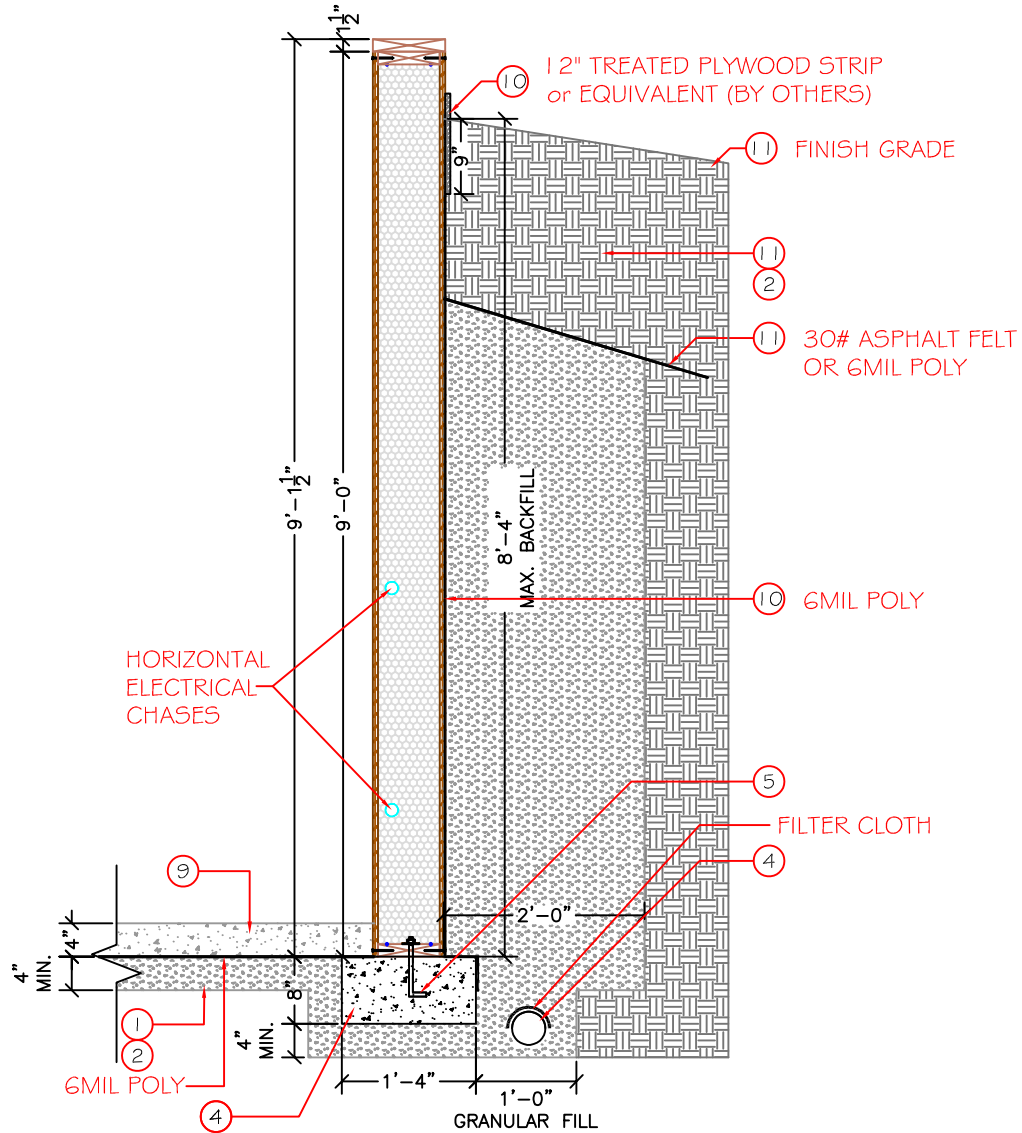
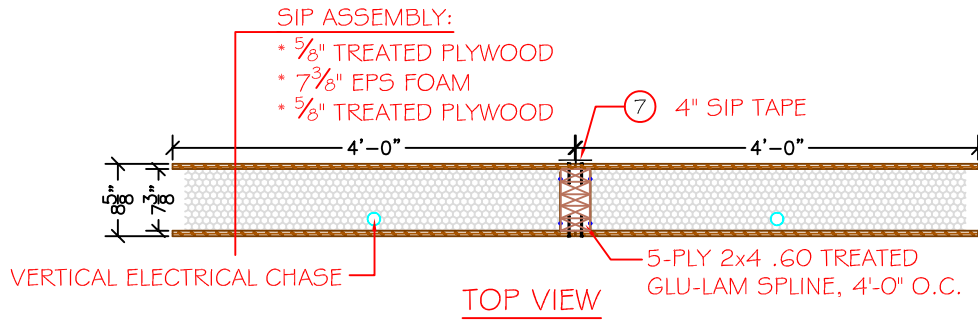

## FOUNDATION DETAIL

NOT TO SCALE

SECTION  
NOT TO SCALE

DETAIL TITLE : BELOW GRADE 8' FOUNDATION SIP

DETAIL NO. : FD-202

PAGE NO. : 5

UPDATED : 3/2024



**EXTREME PANEL**  
TECHNOLOGIES

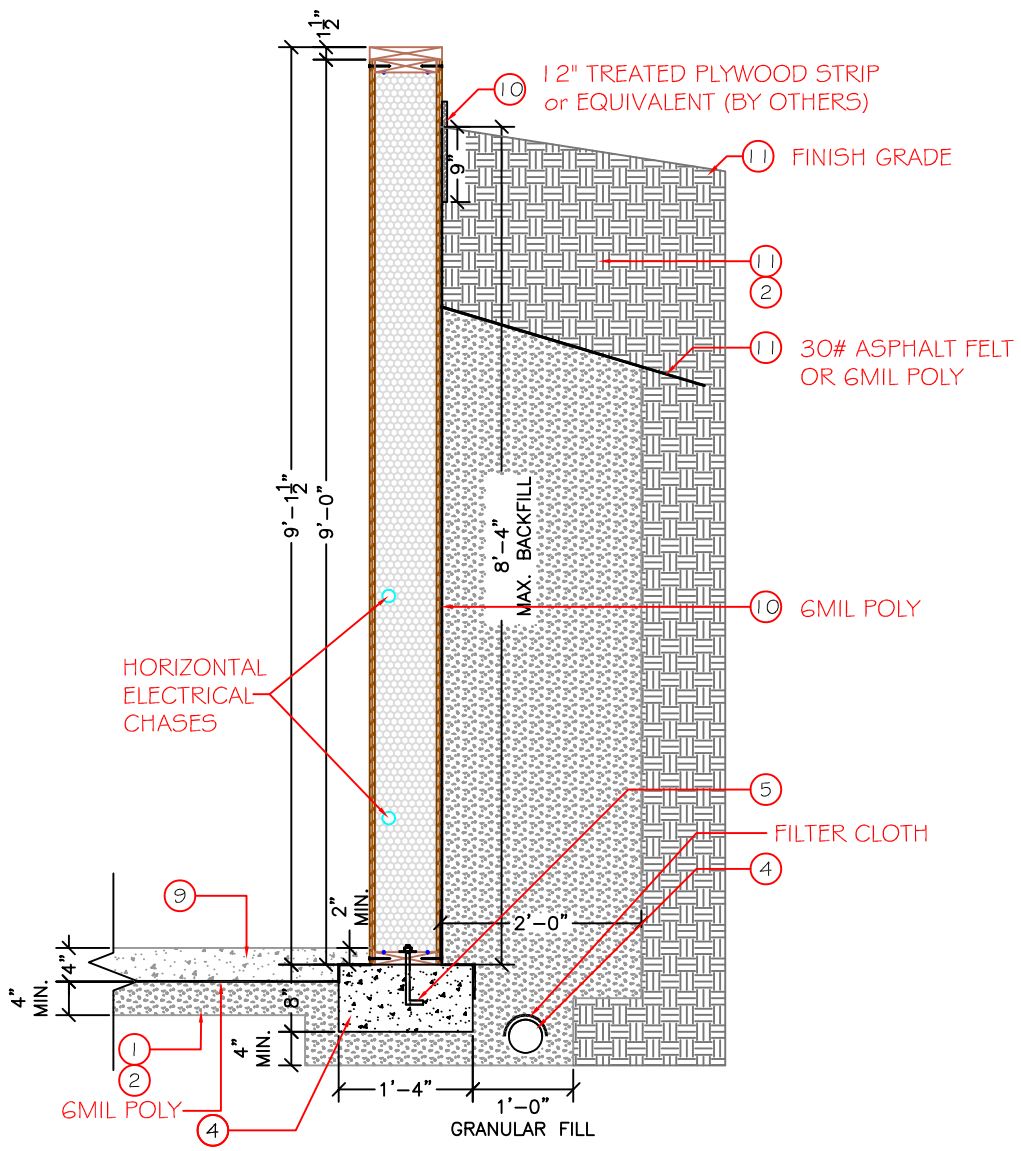
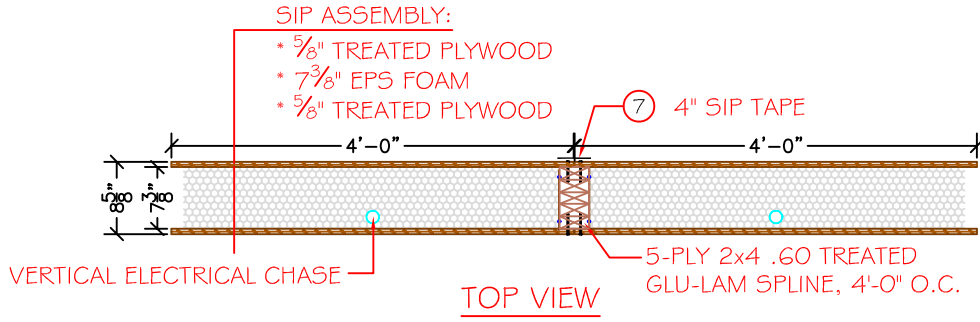

**FOUNDATION DETAIL**  
NOT TO SCALE

OPTIONAL CONCRETE FLOOR POURED AGAINST SIP FOUNDATION WALL

SECTION  
NOT TO SCALE

DETAIL TITLE : BELOW GRADE 8' FOUNDATION SIP  
 DETAIL NO. : FD-202-1  
 PAGE NO. : 6  
 UPDATED : 3/2024





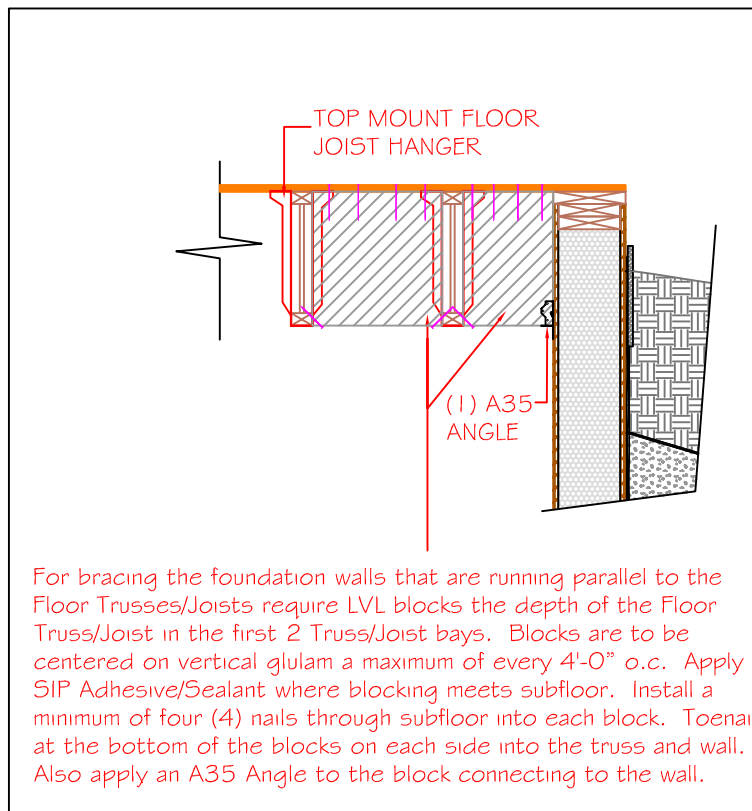
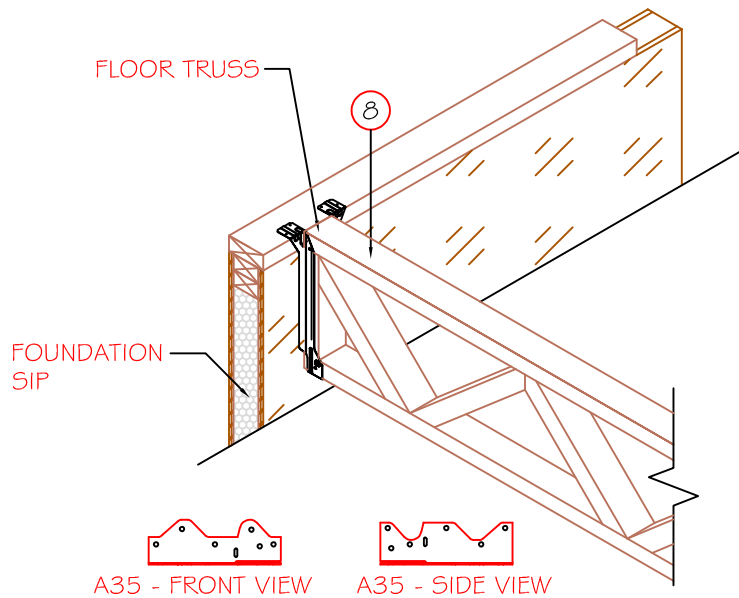

SECTION  
NOT TO SCALE

DETAIL TITLE : BRACING DETAIL (JOIST HANGERS)

DETAIL NO. : BD-101

PAGE NO. : 7

UPDATED : 3/2024



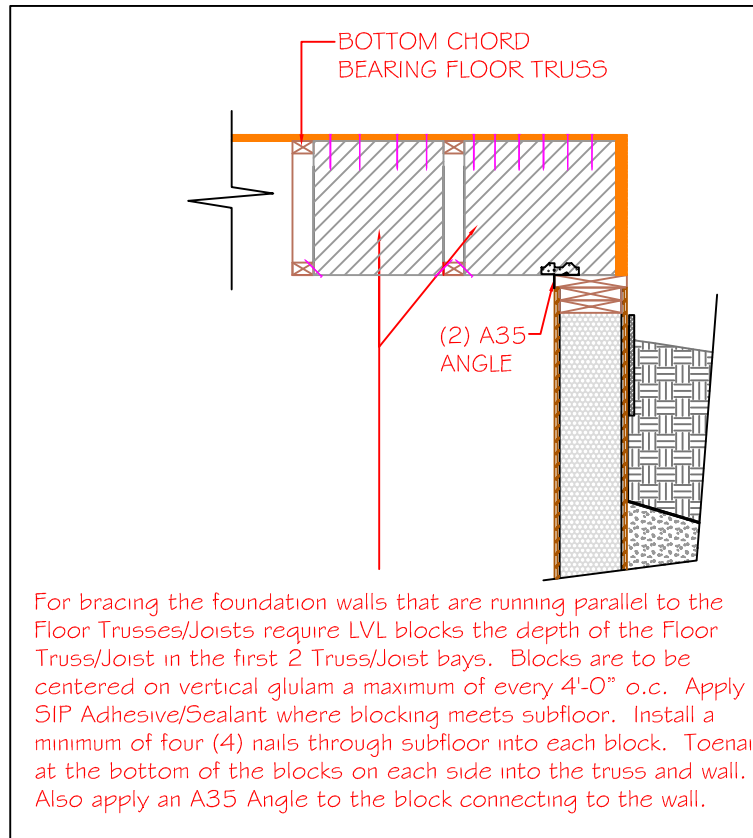
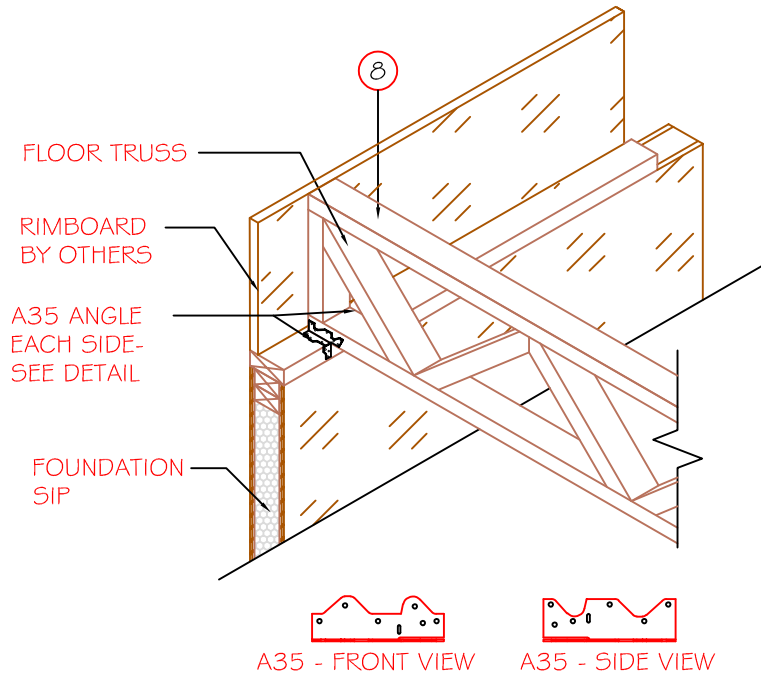

SECTION  
NOT TO SCALE

DETAIL TITLE : BRACING DETAIL (BTM. CHORD BRG.)  
 DETAIL NO. : BD-102  
 PAGE NO. : 8  
 UPDATED : 3/2024



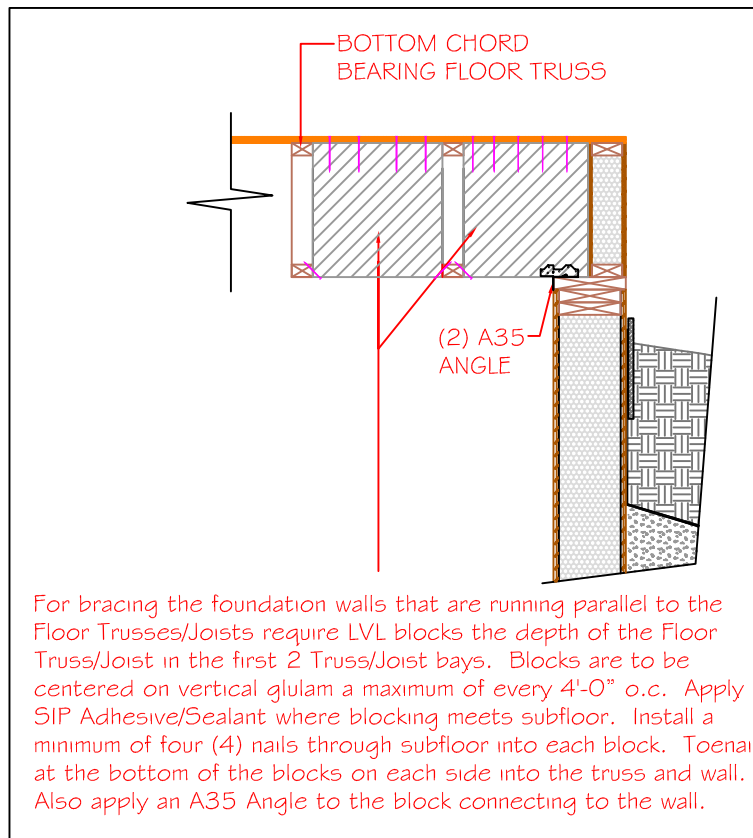
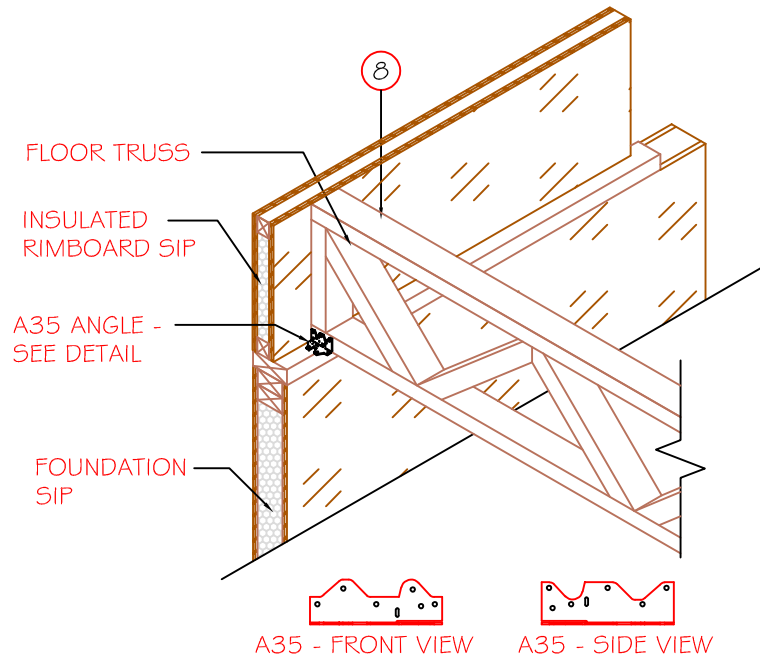

SECTION  
NOT TO SCALE

DETAIL TITLE : BRACING DETAIL (BTM. CHORD BRG.)

DETAIL NO. : BD-103

PAGE NO. : 9

UPDATED : 3/2024



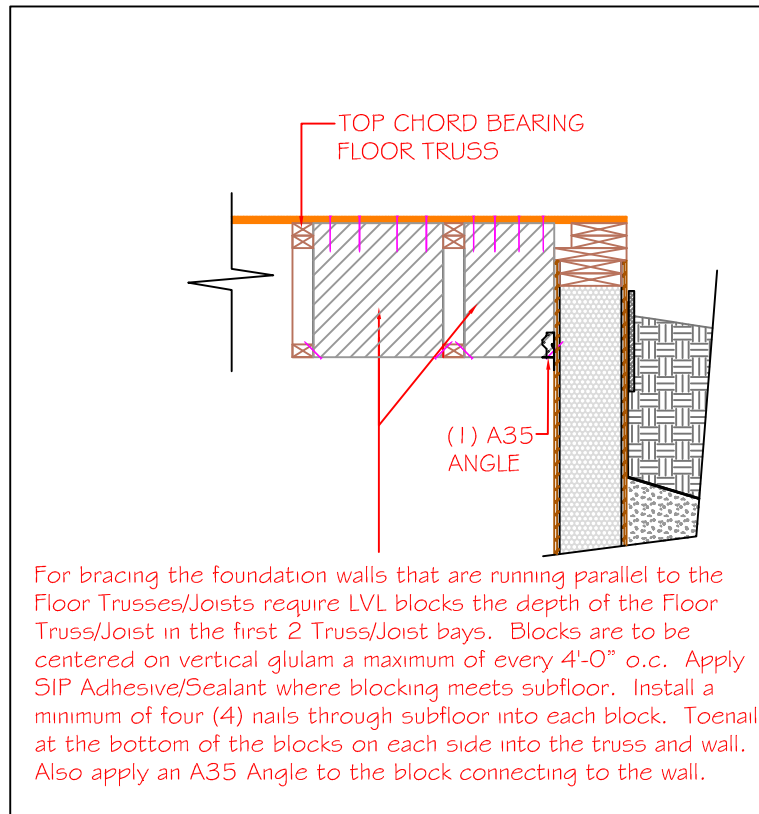
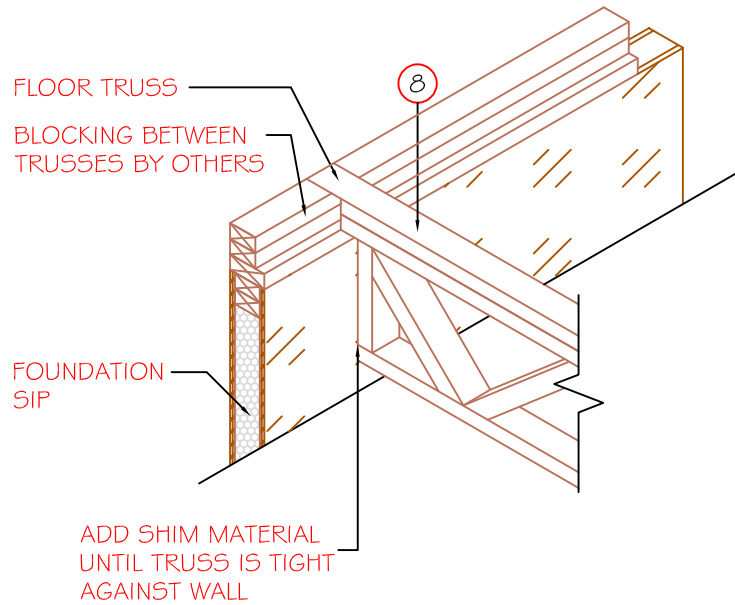

SECTION  
NOT TO SCALE

DETAIL TITLE : BRACING DETAIL (TOP CHORD BRG.)  
 DETAIL NO. : BD-104  
 PAGE NO. : 10  
 UPDATED : 3/2024

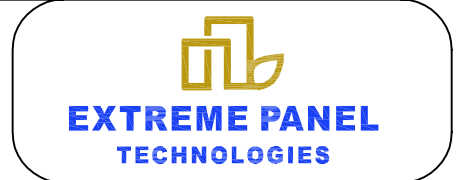

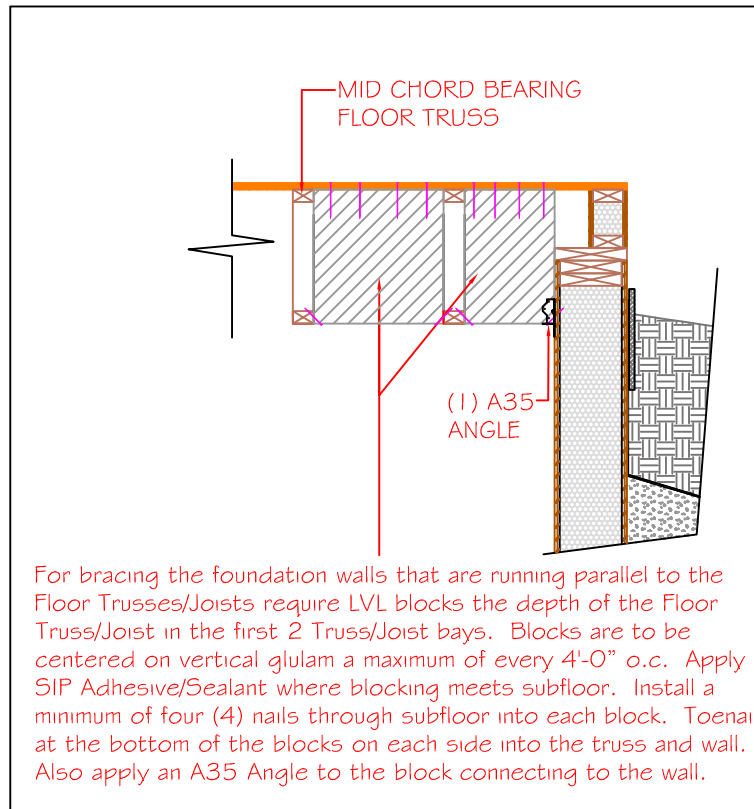
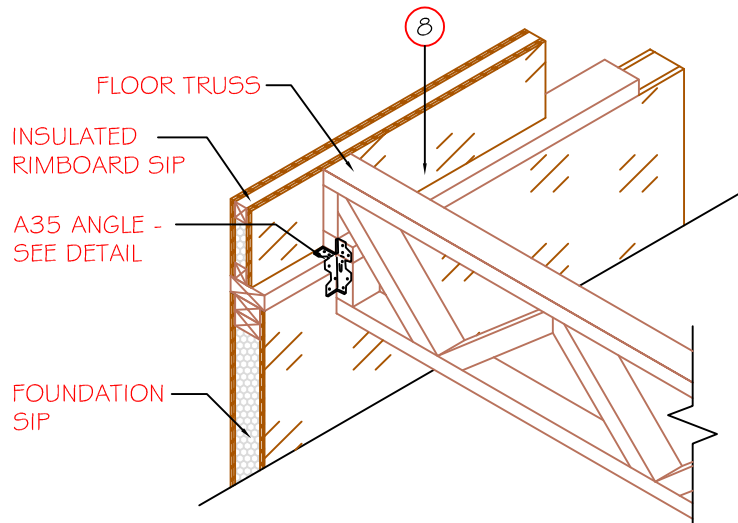

SECTION  
NOT TO SCALE

DETAIL TITLE : BRACING DETAIL (MID CHORD BRG.)

DETAIL NO. : BD-105

PAGE NO. : 11

UPDATED : 3/2024



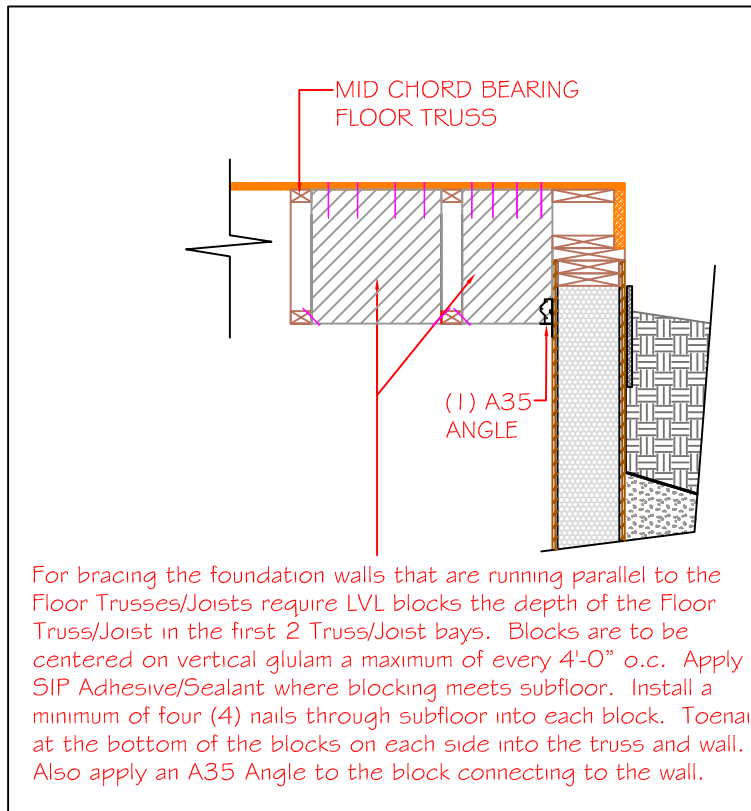
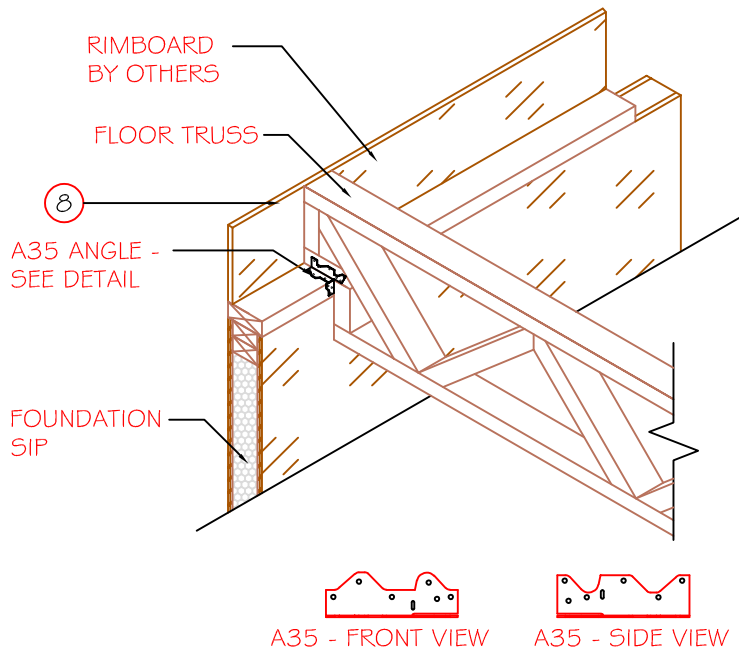

SECTION  
NOT TO SCALE

DETAIL TITLE : BRACING DETAIL (MID CHORD BRG.)

DETAIL NO. : BD-106

PAGE NO. : 12

UPDATED : 3/2024



## SITE CONSIDERATIONS

### SOIL CONDITIONS

The type of soil and general grading conditions at the building site are factors in determining foundation construction details such as footing design, backfill and drainage provisions.

Soils are classified by their composition and how they drain. Table 1 lists common soil types and their properties. Soil classifications for most areas are list-

ed in the standard series of soil surveys published by the U.S. Department of Agriculture's Soil Conservation Service.

PWFs may be built in Group I, II, or III soils. In poorly drained Group III soils, granular fill under the slab for basement-type foundations must be at least 6" deep, as opposed to the 4" minimum for Group I

**TABLE 1 – TYPES OF SOILS AND RELATED DESIGN PROPERTIES**

Soil Group	Unified Soil Classification Symbol	Soil Description	Allowable Bearing in Pounds Per Square Foot with Medium Compaction or Stiffness <sup>1</sup>	Drainage Characteristics <sup>2</sup>	Frost Heave Potential	Volume Change Potential Expansion <sup>3</sup>
Group I <i>Excellent</i>	GS	Well-graded gravels, gravel-sand mixtures, little or no fines.	8000	Good	Low	Low
	GP	Poorly graded gravels or gravel-sand mixtures, little or no fines.	8000	Good	Low	Low
	SW	Well-graded sands, gravelly sands, little or no fines.	6000	Good	Low	Low
	SP	Poorly graded sands or gravelly sands, little or no fines.	5000	Good	Low	Low
	GM	Silty gravels, gravel-sand-silt mixtures.	4000	Medium	Medium	Low
	SM	Silty sand, sand-silt mixtures.	4000	Medium	Medium	Low
Group II <i>Fair to Good</i>	GC	Clayey gravels, gravel-sand-clay mixtures.	4000	Medium	Medium	Low
	SC	Clayey sands, sand-clay mixture.	4000	Medium	Medium	Low
	ML	Inorganic silts and very fine sands, rock flour, silty or clayey fine sands or clayey silts with slight plasticity.	2000	Medium	High	Low
	CL	Inorganic clays of low to medium plasticity, gravelly clays, sandy clays, silty clays, lean clays.	2000	Medium	Medium	Medium <sup>4</sup>
Group III <i>Poor</i>	CH	Inorganic clays of high plasticity, fat clays.	2000	Poor	Medium	High <sup>4</sup>
	MH	Inorganic silts, micaceous or diatomaceous fine sandy or silty soils, elastic silts.	2000	Poor	High	High
Group IV <i>Unsatisfactory</i>	OL	Organic silts and organic silty clays of low plasticity.	400	Poor	Medium	Medium
	OH	Organic clays of medium to high plasticity, organic silts.	-0-	Unsatisfactory	Medium	High
	Pt	Peat and other highly organic soils.	-0-	Unsatisfactory	Medium	High

<sup>1</sup> Allowable bearing value may be increased 25 percent for very compact, coarse grained gravelly or sandy soils or very stiff fine-grained clayey or silty soils. Allowable bearing value shall be decreased 25 percent for loose, coarse-grained gravelly or sandy soils, or soft, fine-grained clayey or silty soils.

<sup>2</sup> The percolation rate for good drainage is over 4 inches per hour, medium drainage is 2 to 4 inches per hour, and poor is less than 2 inches per hour.

<sup>3</sup> For expansive soils, contact local soils engineer for verification of design assumptions.

<sup>4</sup> Dangerous expansion might occur if these soil types are dry but subject to future wetting.